

CUT & PEEL EASY INSTALLATION

PermOseal® Multiple **3 in 1** Size FLASHING



Knowing exactly what size vent pipes will be at a job site when you arrive is not always possible.

Carrying inventory in a wide variety of vent pipe flashing sizes can be costly and difficult to manage.

To help you successfully handle the problems associated with a variety of pipe sizes Duraflo® has created the PermOseal® Multi Flashing.

Cut & Peel to fit
1.5" - 3"
Pipe Sizes



3 Sizes in 1!
Cut and Peel for
1.5" to 3" vent
pipe sizes

- UV and Extreme Cold Resistant
- Built in water deflectors
- Fits roof pitches from 2/12 to 12/12
- Patent Pending

duraflo.com
WE KNOW VENTILATION

by **canplas**®

an OAliaxis company



PermOseal® Multiple **3 in 1** Size FLASHING

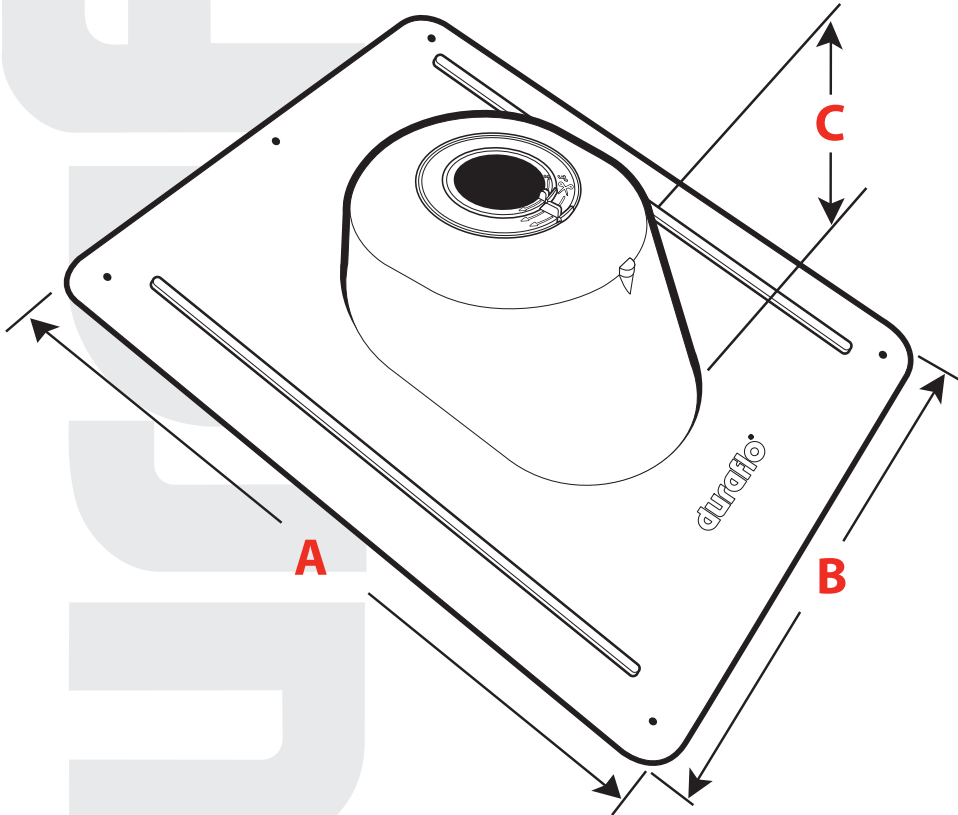

Dimensions:

MODEL: 551233BL
1.5" - 3" Pipe Size

A: 15"
B: 12"
C: 4"

Based on feedback from the roofing community the new 3in1 is easy to use and creates a durable seal for all pipe sizes. By simply making a small cut and peeling away the inner rings as required 3 pipe sizes can be flashed and sealed perfectly with one product.

COLOR	PART #	CTN. QTY.	WT.CTN. (LBS.)
PIPE SIZE 1.5" to 3"			
Black	551233BL	12	6

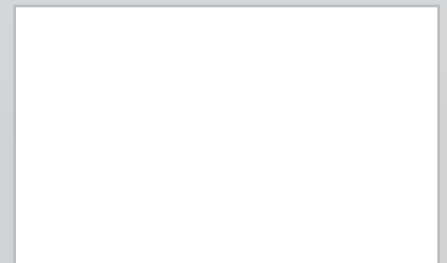

CANADA

Canplas Industries Ltd.
P.O. Box 1800, 500 Veterans Dr.
Barrie, Ontario
Canada L4M 4V3
Tel: (705) 726-3361
Fax: (705) 726-8991
Toll Free: 1-800-461-5300

Canplas Industries Ltd.
11408 - 163rd Street
Edmonton, Alberta,
Canada T5M 3T3
Tel: (780) 451-3206
Fax: (780) 452-0536
Email: prairie.sales@canplas.com

Canplas Industries Ltd.
9489 - 200 Street, Unit 201
Langley, B.C.
Canada V1M 3A7
Tel: (604) 455-0432
Fax: (604) 455-0452
Email: bc.sales@canplas.com

USA

Canplas LLC
11402 East 53rd Ave., Suite 200
Denver, Colorado
U.S.A. 80239
Tel: (303) 373-1918
Fax: (303) 373-1923
Toll Free: 1-888-461-5307

E-mail: duraflo@canplas.com
www.duraflo.com

canplas®

an *Aliaxis* company