

WeatherPRO[®] Series **Turbo Turbine Ball Replacement Cap**

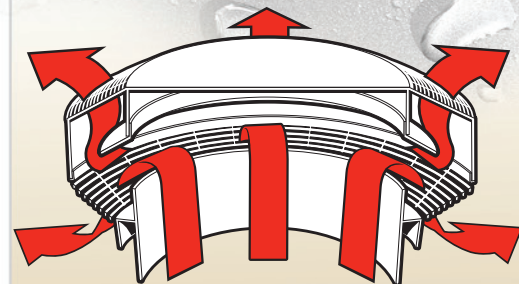

Replaces traditional "squeaking" turbines
without removing existing vent base or shingles!



- **Superior air flow**
- **Installs over existing 12" and 14" bases**
- **No maintenance**



WeatherPRO[®] Series **Turbo Guard**

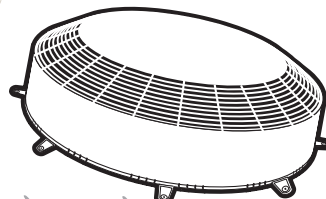

Install WeatherPRO[®] Series Turbo Guard over existing roof vents to eliminate weather infiltration

- **Installs easily without removing vents or shingles**

duraflo.com
WE KNOW VENTILATION

www.duraflo.com

CAN: 1-800-461-5300 USA: 1-888-461-5307

canplas

an OAliaxis company



WeatherPRO[®] Series Turbo Turbine Ball Replacement Cap

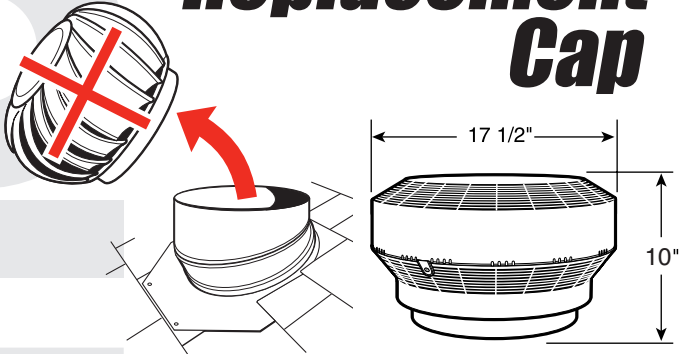

WeatherPRO's patented internal baffles deflect water and snow, allowing it to drain harmlessly out the drainage openings. Designed to allow high airflow while providing excellent defense against weather infiltration.

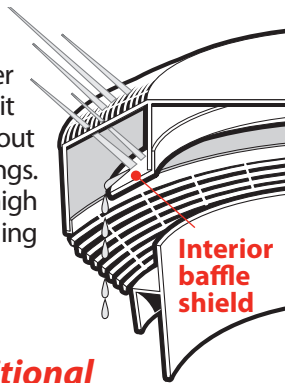

- Replaces traditional "squeaking" turbines easily without removing existing vent base or shingles
- Fits 12" and 14" bases
- 117 sq. in. net free area
- Available in black, brown, gray or weatherwood UV resistant polypropylene
- WeatherPRO[®] Series Turbo Turbine Replacement Cap resists crushing, denting and peeling

DESCRIPTION	PART #	CTN. QTY.	WT.CTN. (LBS.)
Black	6001BL	1	3
Brown	6001BR	1	3
Gray	6001G	1	3
Weatherwood	6001WW	1	3



WeatherPRO[®] Series Turbo Guard

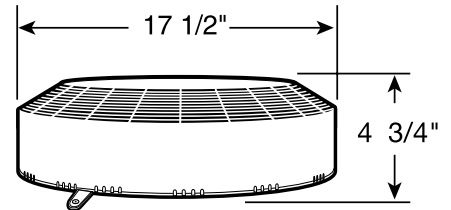
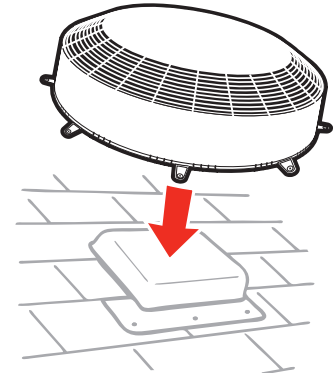

- Install WeatherPRO[®] Series Turbo Guard over existing roof vents to eliminate weather infiltration
- Installs easily without removing existing vents or shingles
- Simulates the Duraflo WeatherPRO[®] Series PRO50 baffle system to ward off driving weather
- Available in black, brown, gray or weatherwood UV resistant polypropylene
- WeatherPRO[®] Series Turbo Guard resists crushing, denting and peeling

DESCRIPTION	PART #	CTN. QTY.	WT.CTN. (LBS.)
Black	6070BL	6	6
Brown	6070BR	6	6
Gray	6070G	6	6
Weatherwood	6070WW	6	6

CANADA

Canplas Industries Ltd.
P.O. Box 1800, 500 Veterans Dr.
Barrie, Ontario
Canada L4M 4V3
Tel: (705) 726-3361
Fax: (705) 726-8991
Toll Free: 1-800-461-5300

Canplas Industries Ltd.
11408 - 163rd Street
Edmonton, Alberta,
Canada T5M 3T3
Tel: (780) 451-3206
Fax: (780) 452-0536
Email: prairie.sales@canplas.com

Canplas Industries Ltd.
9489 - 200 Street, Unit 201
Langley, B.C.
Canada V1M 3A7
Tel: (604) 455-0432
Fax: (604) 455-0452
Email: bc.sales@canplas.com

USA

Canplas LLC
11402 East 53rd Ave., Suite 200
Denver, Colorado
U.S.A. 80239
Tel: (303) 373-1918
Fax: (303) 373-1923
Toll Free: 1-888-461-5307

E-mail: duraflo@canplas.com
www.duraflo.com

canplas[®]

an OAliaxis company