

# WeatherPRO<sup>®</sup> Series **PRO Turbo**

Control the Weather

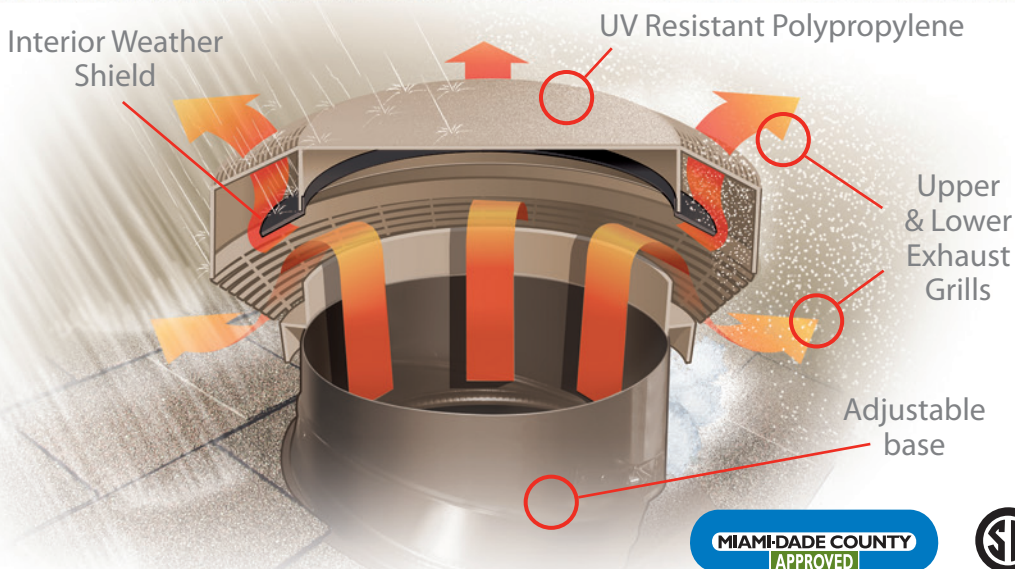

- Superior Air Flow
- No Maintenance
- Interior Baffles Ward off Rain and Snow
- Internal Flow Through Technology
- Eliminates traditional turbine "squeaking"
- 117 sq. in. net free area
- Available in black, brown or weatherwood UV resistant polypropylene
- Turbo Cap resists crushing, denting and peeling
- Extreme cold & heat resistant
- Adjustable base
- CSA & Dade County approved  
U.S. Patent 7,774,999



**duraflo**.com  
WE KNOW VENTILATION

[www.duraflo.com](http://www.duraflo.com)

CAN: 1-800-461-5300 USA: 1-888-461-5307

**canplas**<sup>™</sup>

an *O*Aliaxis company

**Model:** WeatherPRO® PROTurbo, model # 6000

# WeatherPRO<sup>®</sup> Series PROTurbo

Control the Weather

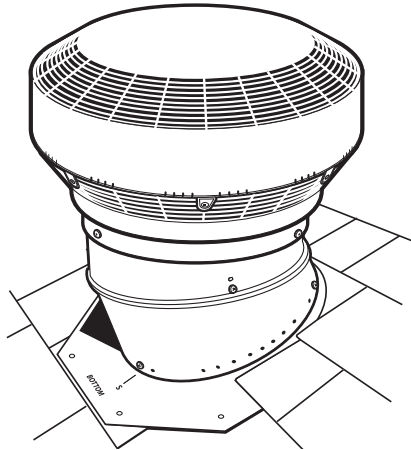

**duraflo**.com  
WE KNOW VENTILATION

**Description:**

- No internal or external moving parts – requires no maintenance
- Net free venting area of 117 sq-in / 755 sq-cm
- One Turbo will ventilate 1000 sq ft of attic space (approx) – regardless of wind speed
- Two-piece base fits roof pitches from 3/12 up to 12/12
- Large flashing allows for easy installation
- Injection molded from pure, high grade polypropylene with premium UV inhibitor additives
- Available as a full unit (including base) or as replacement top only

**Approved Certifications:**



- CSA certified - Plastic Type B roof vents, for installation on sloping surfaces
- Miami Dade High Velocity Hurricane Zone certified: NOA 07.1023.01

**Durability:**

Engineered to resist denting, peeling, extreme heat and cold impact to -40

**Colors:**

Black, Brown, Weatherwood

**Weather Protection :**



WeatherPRO's patented internal baffles deflect water and snow, allowing it to drain harmlessly out the drainage openings. Designed to allow high airflow while providing excellent defense against weather infiltration.

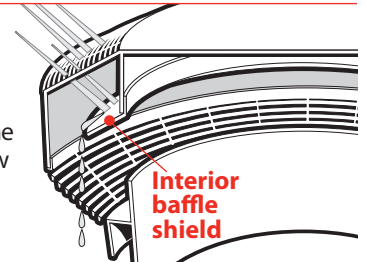

**Dimensions:**

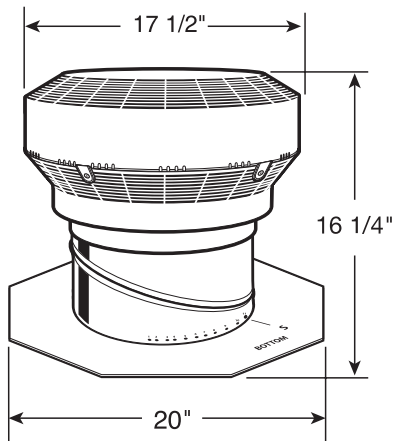

**• Superior Air Flow**

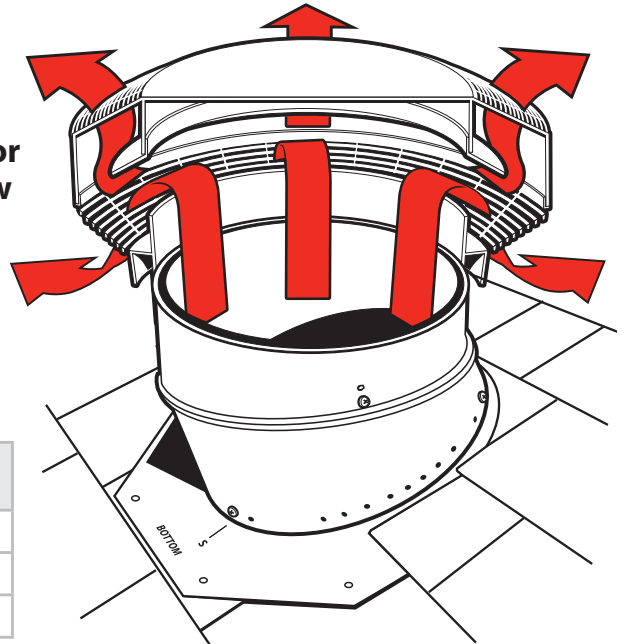

DESCRIPTION	PART #	SIZE	CTN. QTY.	WT.CTN. (LBS.)
Black	6000BL	17 1/2" x 20" x 16 1/4"	1	3
Brown	6000BR	17 1/2" x 20" x 16 1/4"	1	3
Weatherwood	6000WW	17 1/2" x 20" x 16 1/4"	1	3

**CANADA**

**Canplas Industries Ltd.**  
P.O. Box 1800, 500 Veterans Dr.  
Barrie, Ontario  
Canada L4M 4V3  
Tel: (705) 726-3361  
Fax: (705) 726-8991  
**Toll Free: 1-800-461-5300**

**Canplas Industries Ltd.**  
11408 - 163rd Street  
Edmonton, Alberta,  
Canada T5M 3T3  
Tel: (780) 451-3206  
Fax: (780) 452-0536  
Email: prairie.sales@canplas.com

**Canplas Industries Ltd.**  
9489 - 200 Street, Unit 201  
Langley, B.C.  
Canada V1M 3A7  
Tel: (604) 455-0432  
Fax: (604) 455-0452  
Email: bc.sales@canplas.com

**USA**

**Canplas LLC**  
11402 East 53rd Ave., Suite 200  
Denver, Colorado  
U.S.A. 80239  
Tel: (303) 373-1918  
Fax: (303) 373-1923  
**Toll Free: 1-888-461-5307**

E-mail: [duraflo@canplas.com](mailto:duraflo@canplas.com)  
[www.duraflo.com](http://www.duraflo.com)

**canplas**<sup>®</sup>

an OAliaxis company